

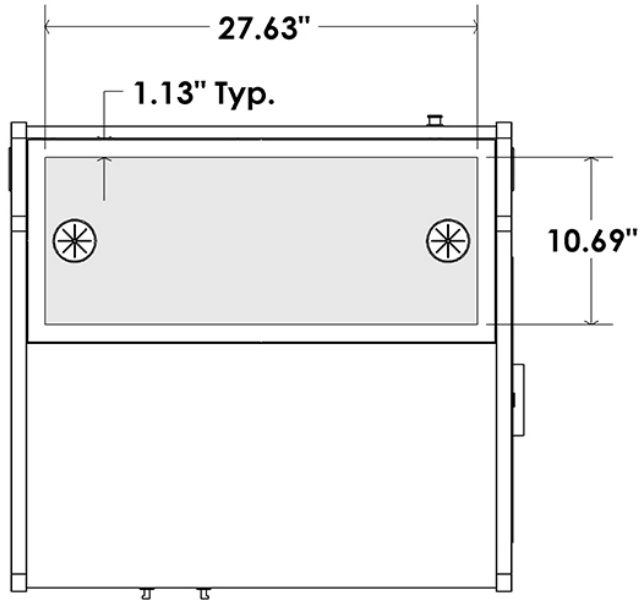

Please indicate custom cutout location on the drawing (s) below

4 Custom Cutout Option (Extra charges will apply)

Top Rear Removable Panel  
cutout in flat position



Same  
Top Rear Removable Panel  
cutout in a wedge position  
(see assembly instructions)

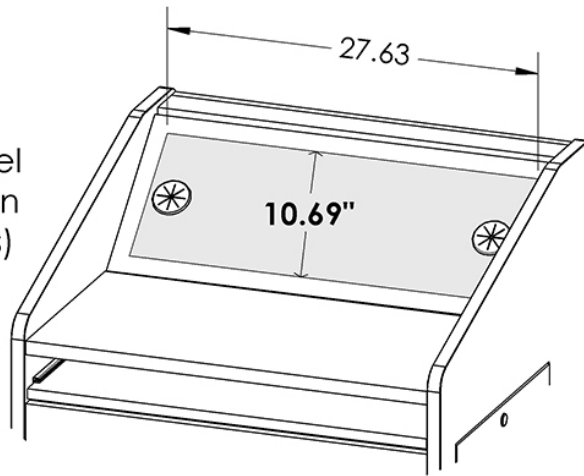

Code **CO** No Custom Cutout

Code **CC** Custom Cutout (Specify on Cutout Area Above)

■ Cutout Area - Flat or Wedge Position (27.63"W X 10.69"D)